

## 2018+ JL Rear Axle Skid Plate | Dana 44 SPJL-10

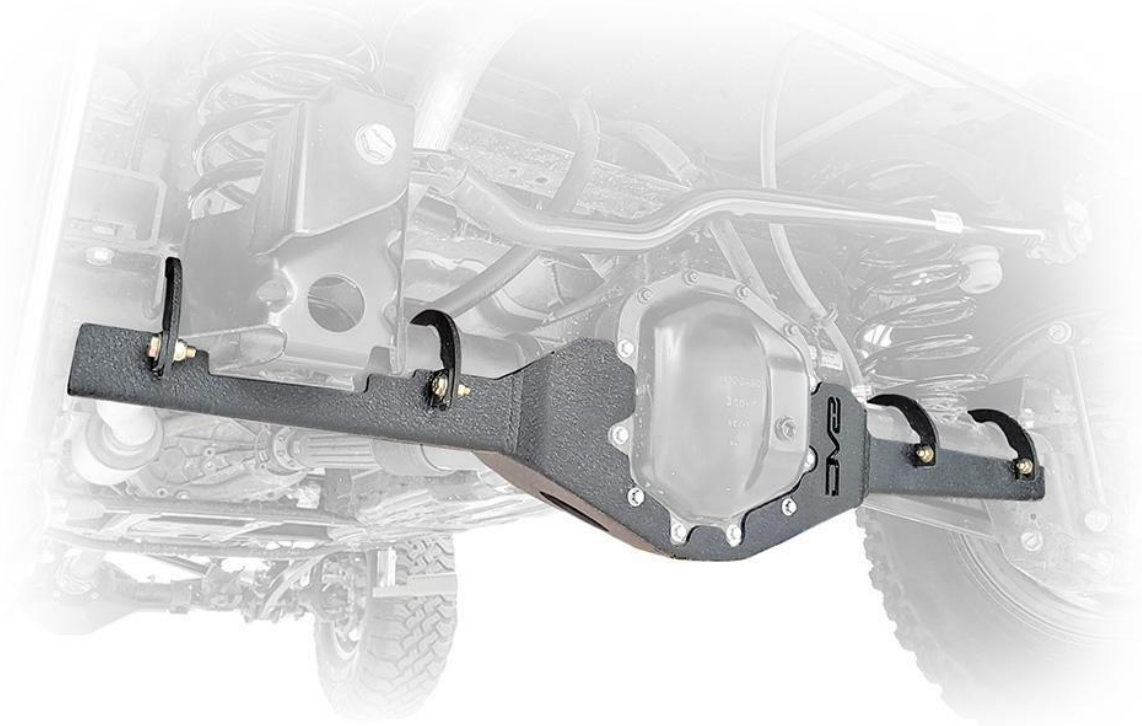

### WARNINGS/CAUTIONS BEFORE STARTING INSTALLATION

**Before you install this kit – Read and understand all instructions, warnings, cautions, and notes contained in this installation instruction guide. Consult your vehicle owner's manual for proper disconnection of electrical and lifting of vehicle if required for installation of this product.**

This install may require some technical skills and knowledge of basic mechanical work. If you do not feel that you are capable of performing this install please take this product to a trained professional.

After reading this guide please contact us with any questions or concerns before installing product.  
Customer Service: 855-680-9595

*DV8 Offroad is not responsible for any bodily injury or harm to you or your vehicle as a result of an improper install.*

Proper installation of this kit requires knowledge of the factory recommended procedures for removal and installation of original equipment components. We recommend that the factory shop manual and any special tools needed to service your vehicle be on hand during the installation. Installation of this kit without proper knowledge of the factory recommended procedures may affect the performance of these components and the safety of the vehicle.

• *Always wear eye protection when operating power tools.* •

*Inspect all contents of this package to make sure product is not damaged and all installation hardware has been included. If parts are missing from kit, please be prepared to provide the following information:*

1. Name of purchase location
2. Bar Code on side of box
3. Date above bar code
4. Date inside box cover



1. Begin by removing all parts and hardware and inspecting them for any abnormalities or shipping damage. If you have any questions, please contact the company you purchased the SPJL-10 from.
2. Begin by using a 10mm socket to remove the (4) factory bottom differential cover bolts.  
**NOTE:** You will not have any issues with leaking oil if only these (4) are removed. Do not pull or pry on differential cover.



3. Once bolts are removed, hold your new axle skid plate up to the axle aligning these (4) holes. Hand screw in the (4) factory bolts. Do not tighten at this point. The weight of the skid plate should be able to be held on these loose bolts for now.



4. Swing around to the front. Using the 15mm head bolts with lock washers and flat washers, loosely hang the front straps onto the front of the differential. Do not tighten these just yet.



5. Begin by placing the axle straps in place across the axle. Using the 13mm head bolts, 2 flat washers, and the nylon lock nuts. Do not tighten these just yet.



6. Note the orientation of the axle straps. On the two outside straps (closest to the tires) make sure to clear under the parking brake cables.

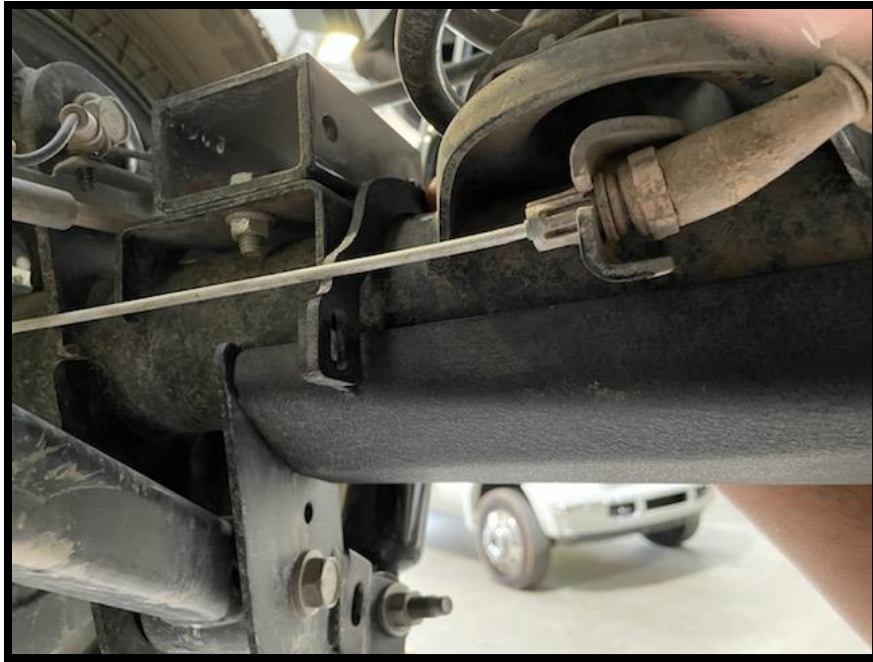

7. Once all items are mounted, begin at the differential cover bolts. Push up the cover as high it will go and tighten the factory bolts to manufacturer specifications of 28-33ft-lbs.



8. Next, tighten down both front straps. Push up on the bottom of the skid plate as high as it will go and push down on the top of the strap to get a tight clamp on the axle.

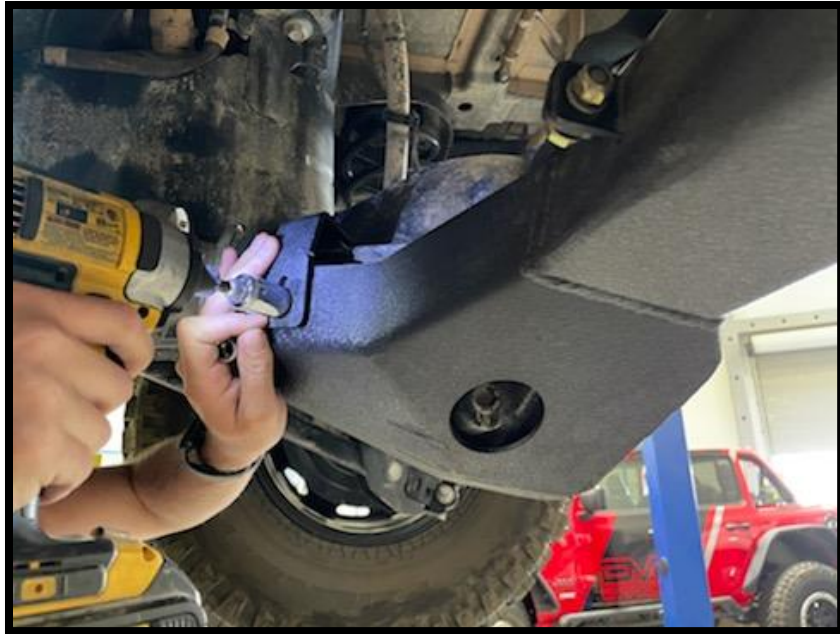

9. Lastly, tighten front and rear bolts for the (4) remaining axle straps. Check to make sure all skid plate parts clear suspension and brake components.



If you have any questions, please feel free to contact us!