

## OVERHEAD MOLLE PANEL

21+ FORD 2 DOOR BRONCO

MPBR-09



### TOOLS REQUIRED

- Trim Clip Tool
- #4 Allen Bit
- 13mm Socket
- 8mm, 10mm, Wrenches
- "L" Shaped T20 Torx Bit
- T50 Torx Bit

### SKILL LEVEL

- Novice/Intermediate
- 1 (you) to 2 persons

Little skill level required, you can easily install it by yourself however, additional help will be useful

### TIME REQUIRED

- 1 Hour

Time to install this should only take about an hour

## WARNINGS/CAUTIONS BEFORE STARTING INSTALLATION

Before you install this kit – Read and understand all instructions, warnings, cautions, and notes contained in this installation instruction guide. Consult your vehicle owner's manual for proper disconnection of electrical and lifting of vehicle if required for installation of this product.

This install may require some technical skills and knowledge of basic mechanical work. If you do not feel that you are capable of performing this install please take this product to a trained professional.

After reading this guide please contact us with any questions or concerns before installing product.  
Customer Service: 855-680-9595

*DV8 Offroad is not responsible for any bodily injury or harm to you or your vehicle as a result of an improper install.*

Proper installation of this kit required knowledge of the factory recommended procedures for removal and installation of original equipment components. We recommend that the factory shop manual and any special tools needed to service your vehicle be on hand during the installation. Installation of this kit without proper knowledge of the factory recommended procedures may affect the performance of these components and the safety of the vehicle

- Always wear eye protection when operating power tools

*Inspect all contents of this package to make sure product is not damaged and all installation hardware has been included. If parts are missing from kit, please be prepared to provide the following information*

1. Name of purchase location
2. Bar Code on side of box
3. Date above bar code
4. Date inside box cover



# INSTALLATION MANUAL

Begin by unpacking all items and inspecting for missing pieces or damage. If you have any concerns, please contact the company the product was purchased from. Extra hardware may be included with the product.

## HARDWARE INCLUDED

- (10) M6X20 Allen
- (10) M6 Lock Nuts
- (20) M6 Flat Washers
- (2) M8x20 Allen Head Bolts
- (2) Enlarge Washers
- (2) Nylon Spacers
- (2) M8x35 Hex Bolts
- (2) M8 Flat Washers

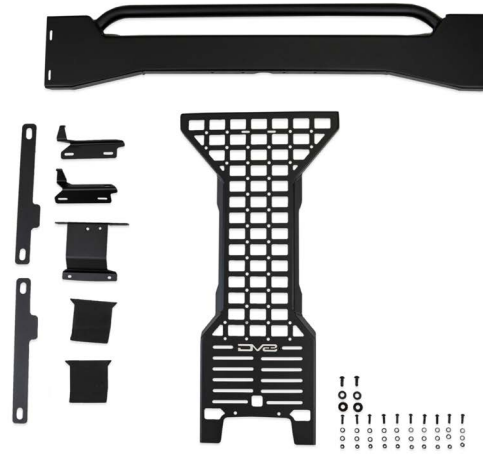

**STEP 1** | Use a trim clip tool to release the panel covering the bolt that secures the sun visor catch to the overhead windshield trim.



**STEP 2** | Use a "L" shaped T-20 Torx bit to remove the sun-visor catch for both sun visors.



# INSTALLATION MANUAL

**STEP 3** | Pull down on the center of the overhead windshield trim to release the clips that are securing it to windshield.



**STEP 4** | Apply the provided foam to both sides of the front mounting bracket.

This will be the squarish shaped bracket with four mounting holes.

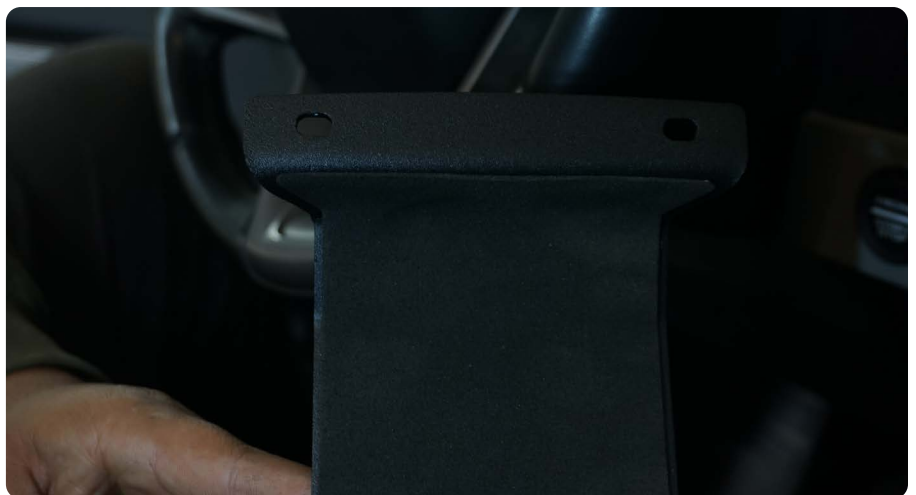

# INSTALLATION MANUAL

**STEP 5** | Use a T50 Torx Bit to remove two bolts securing the soft/hard top mounting brackets.



**STEP 6** | Use a 10mm wrench to remove the nut located between the bolts removed in step 5.



**STEP 7** | Install the front mounting bracket as shown and secure using the factory hardware with a T50 Torx bit and a 10mm wrench.



# INSTALLATION MANUAL

**STEP 8** | Push the trim back into place until the clips are secured.



**STEP 9** | Install the sun visor catches using a "L" Shaped T20 Torx Bit.



**STEP 10** | Use an 8mm wrench to remove the factory roll bar trim bolt.

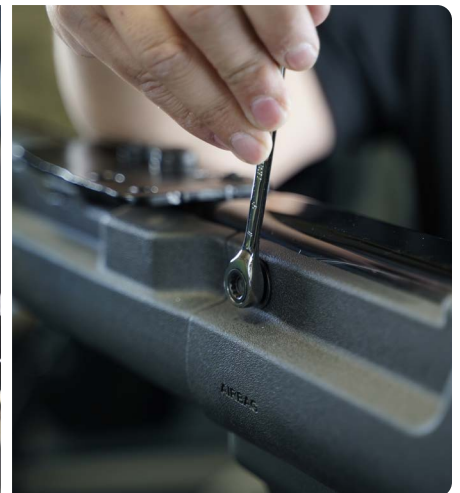

# INSTALLATION MANUAL

**STEP 11** | Install the roll-bar brackets using the factory hardware and make sure the bracket grabs the slotted hole on top of the roll bar.

Leave it loose.

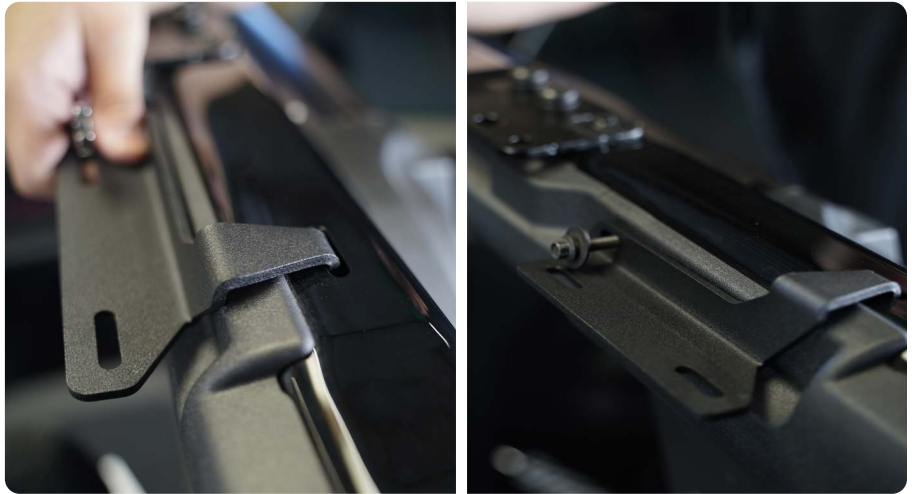

**STEP 12** | Use the provided spacers underneath the pressure mounting plate and loosely secure using the provided M8x35mm hardware.

**Note:** (1) Spacer per side.

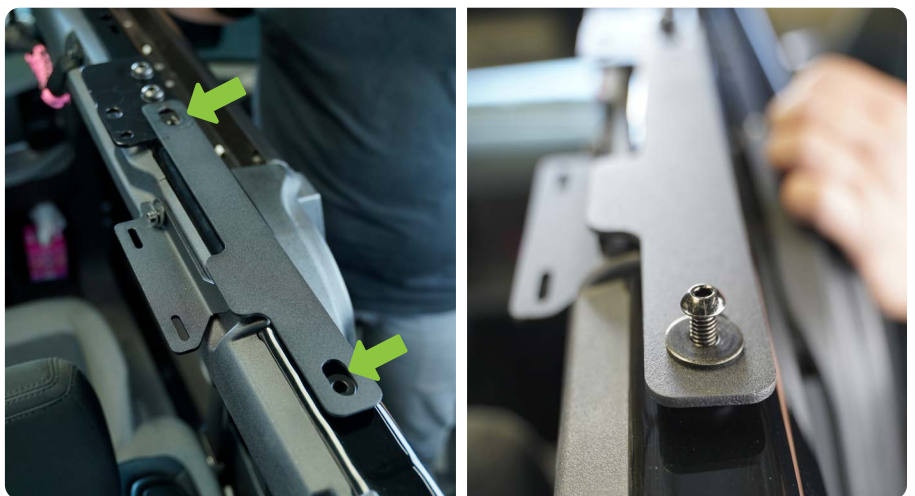

# INSTALLATION MANUAL

**STEP 13** | Loosely install the cross bar with tube facing the rear of the vehicle using the provided M6 hardware.



**STEP 14** | Use a #4 Allen bit and 10mm wrench to secure the M6 hardware holding the cross-brace to the roll bar mounting bracket.

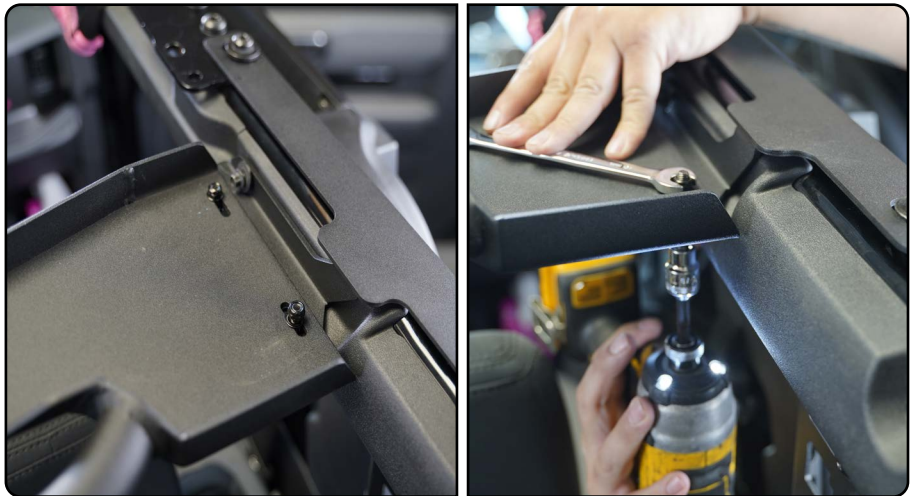

**STEP 15** | Use a #5 allen bit to secure the hardware holding the mounting plate to the roll-bar.

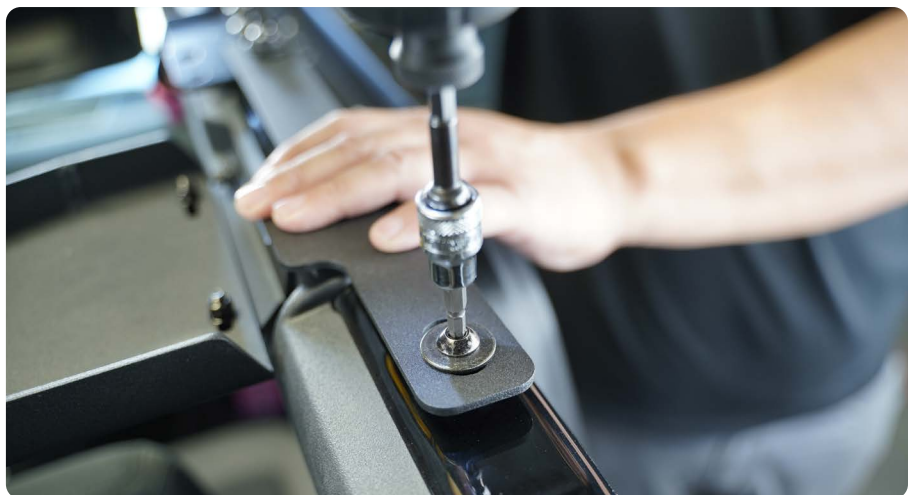

# INSTALLATION MANUAL

**STEP 16** | Install molle panel and loosely secure it to the front mount and cross brace using the provided M6 hardware.

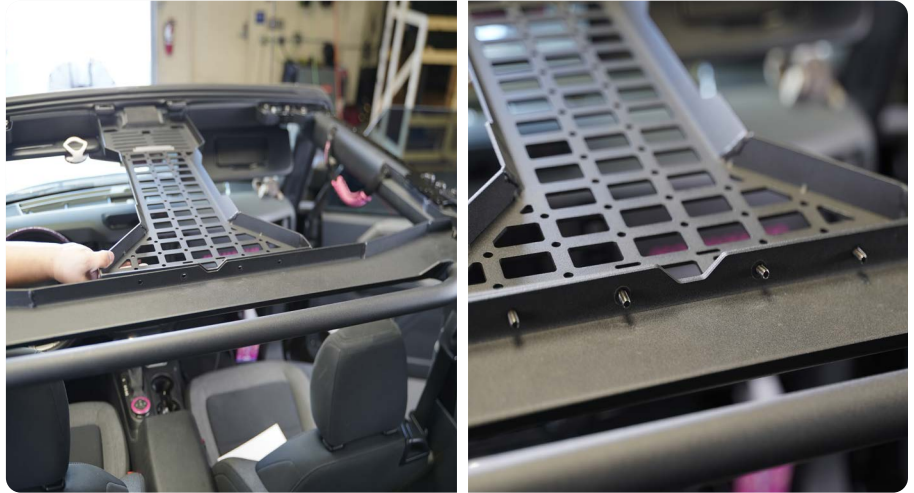

**STEP 17** | Secure the M6 hardware at the front and rear of the molle panel using a #4 Allen bit and 10mm wrench.

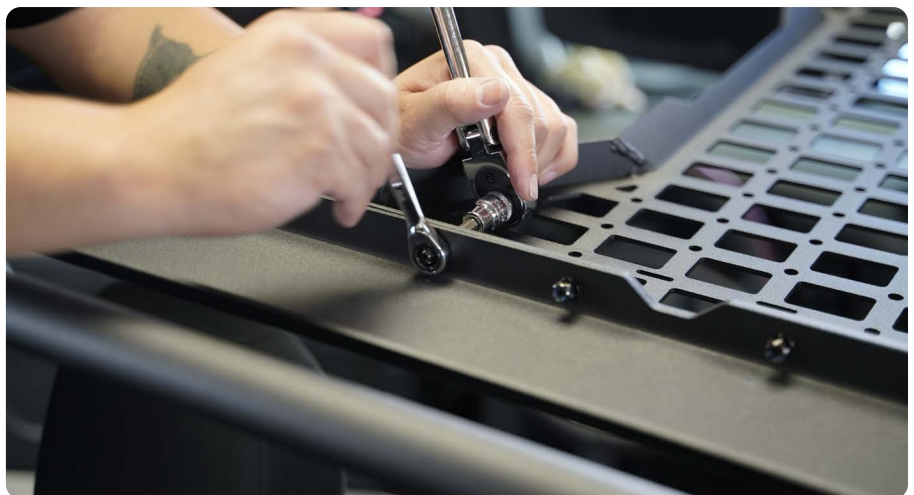



# INSTALLATION MANUAL

**STEP 18** | Use a 8mm wrench to secure the roll-bar bracket.



**STEP 19** | Double check all hardware is secure.

Congratulations, you are finished with your install of the DV8 Overhead Molle.

