

OVERHEAD MOLLE PANEL

21+ FORD BRONCO

MPBR-04



TOOLS REQUIRED

- Trim Clip Tool
- #4 Allen Bit
- 13mm Socket
- 8, 10mm Wrench
- "L" Shaped T20 Torx Bit
- T50 Torx Bit
- T30, T40 Torx Bit (Raptor Only)

SKILL LEVEL

- Novice/Intermediate
 - 1 (you) to 2 persons
- Little skill level required, you can easily install it by yourself however, additional help will be useful

TIME REQUIRED

- 1 Hour
- Time to install this should only take about an hour

WARNINGS/CAUTIONS BEFORE STARTING INSTALLATION

Before you install this kit – Read and understand all instructions, warnings, cautions, and notes contained in this installation instruction guide. Consult your vehicle owner's manual for proper disconnection of electrical and lifting of vehicle if required for installation of this product.

This install may require some technical skills and knowledge of basic mechanical work. If you do not feel that you are capable of performing this install please take this product to a trained professional.

After reading this guide please contact us with any questions or concerns before installing product.
Customer Service: 855-680-9595

DV8 Offroad is not responsible for any bodily injury or harm to you or your vehicle as a result of an improper install.

Proper installation of this kit required knowledge of the factory recommended procedures for removal and installation of original equipment components. We recommend that the factory shop manual and any special tools needed to service your vehicle be on hand during the installation. Installation of this kit without proper knowledge of the factory recommended procedures may affect the performance of these components and the safety of the vehicle

- Always wear eye protection when operating power tools

Inspect all contents of this package to make sure product is not damaged and all installation hardware has been included. If parts are missing from kit, please be prepared to provide the following information

1. Name of purchase location
2. Bar Code on side of box
3. Date above bar code
4. Date inside box cover



INSTALLATION MANUAL

Begin by unpacking all items and inspecting for missing pieces or damage. If you have any concerns, please contact the company the product was purchased from. Extra hardware may be included with the product.

HARDWARE INCLUDED

- (4) M8x30 Hex
- (4) M8 Flat Washers
- (4) M8 Spring Washers
- (10) M6x20 Allen
- (10) M6 Flat Washers
- (20) M6 Flat Washers

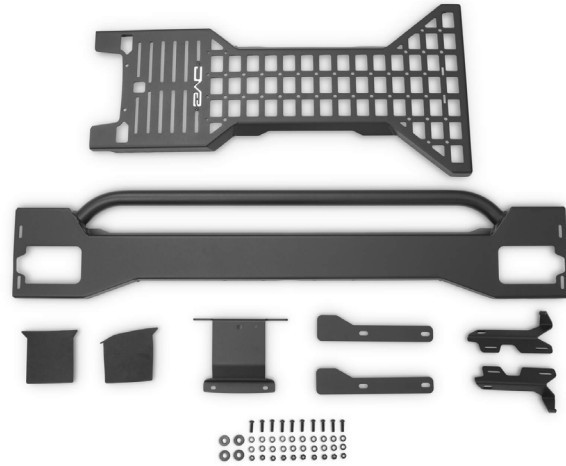

STEP 1 | Use a trim clip tool to release the panel covering the bolt that secures the sun visor catch to the overhead windshield trim.



STEP 2 | Use a "L" shaped T-20 Torx bit to remove the sun-visor catch for both sun visors.



INSTALLATION MANUAL

STEP 3 | Pull down on the center of the overhead windshield trim to release the clips that are securing it to windshield.



STEP 4 | Apply the provided foam to both sides of the front mounting bracket.

This will be the squarish shaped bracket with four mounting holes.



INSTALLATION MANUAL

STEP 5 | Use a T50 Torx bit to remove two bolts securing the soft/hard top mounting brackets.



STEP 6 | Use a 10mm wrench to remove the nut located between the bolts removed in step 5.



STEP 7 | Install the front mounting bracket as shown and secure using the factory hardware with a T50 Torx bit and a 10mm wrench.



INSTALLATION MANUAL

STEP 8 | Push the trim back into place until the clips are secured.



STEP 9 | Install the sun visor catches using a "L" shaped T20 Torx bit.



INSTALLATION MANUAL

STEP 10 | If installing on a Bronco Raptor, begin by using a T30 to remove the two outside over panels of the overhead cross bar.

If installing on any other model other than Raptor, continue to step 12.

Once bolts are removed, pull panel straight down to release the clips.

NOTE: The factory overhead crossbar will not be reinstalled.



STEP 11 | Using a T40 torx tool, remove the four bolts securing the crossbar to the mounting brackets.

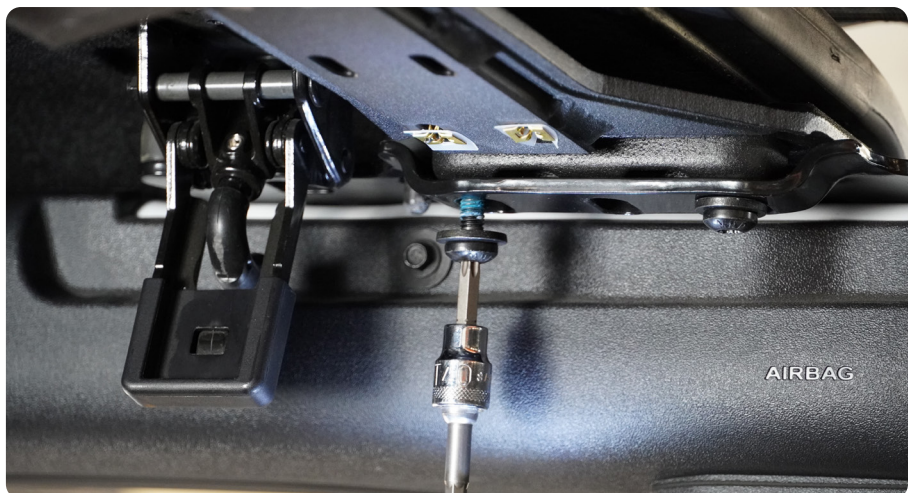

INSTALLATION MANUAL

STEP 12 | *Hard Top Models:* remove (2) of the three factory bolts on each side securing the hardtop mounting brackets using a T50 Torx bit.

Note: For soft top install skip to step 16.



STEP 13 | Use a 8mm wrench to remove the bolt on the interior of the roll bar.



STEP 14 | Loosely Install the roll bar brackets using the factory hardware and an 8mm socket. Make sure the bracket grabs the slotted hole on top of the roll bar.



INSTALLATION MANUAL

STEP 15 | Loosely install the provided pressure plate on top of the factory hardtop mounting plate using the factory hardware and an T50 torx tool.

Note: Skip to step 18 to continue installing the cross bar and molle panel.



INSTALLATION MANUAL

STEP 16 | Soft Top Models:
Loosely install the roll-bar brackets using the factory hardware and an 8mm socket. Make sure the bracket grabs the slotted hole on top of the roll bar.



STEP 17 | Place the provided spacers over the factory threaded holes on top of the roll bar.

Install the provided pressure mounting plate over the provided spacers and loosely secure in place using the provided M8 hardware and a 13mm socket.



INSTALLATION MANUAL

STEP 18 | Loosely install the cross bar with tube facing the rear of the vehicle using the provided M6 hardware, #4 Allen tool and 10mm socket/wrench.



STEP 19 | Install the Molle panel, loosely secure it to the front mount and cross brace using the provided M6 hardware, #4 Allen tool and 10mm socket/wrench.



INSTALLATION MANUAL

STEP 20 | Use a #4 Allen bit and 10mm wrench to secure the hardware holding the cross-brace to the roll bar mounting bracket.



STEP 21 | Use an 8mm wrench to secure the factory hardware holding the roll bar bracket to the roll bar.

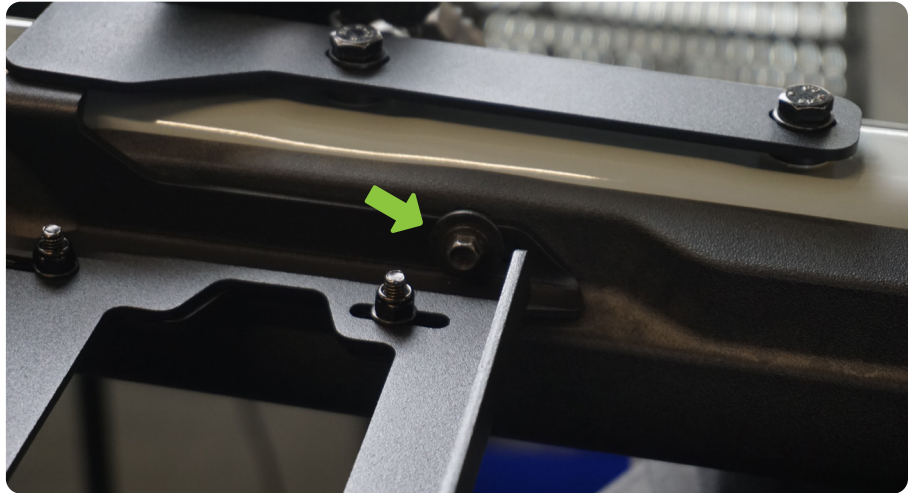

STEP 22 | For soft top models, use a 13mm socket to secure the pressure plate hardware.

For hard top models, use a T50 torx tool to secure the pressure plate and factory mounting plate.

This will help secure the roll bar mounting bracket to the roll bar.



INSTALLATION MANUAL

STEP 23 | Secure the M6 hardware at the front and rear of the Molle panel using a #4 Allen tool and 10mm wrench.



INSTALLATION MANUAL

STEP 24 | Congrats! You are finished with the install of the 21+ Bronco Overhead Molle Panel.

