

CENTER MOUNT

2022+ (3RD GEN) TOYOTA TUNDRA

FBTT2-05



TOOLS REQUIRED

- 10mm, 21mm, 22mm Sockets
- 10mm, 18mm, 19mm, 21mm, 22mm Wrenches
- 4mm Allen Bit
- Trim Clip Tool
- Flat Head Screwdriver
- Preferred cutting tool
- File or Sandpaper
- Marker/Sharpie

SKILL LEVEL

- Intermediate/Difficult
- 2 persons

Intermediate skill level required. Assistance is necessary for installation.

TIME REQUIRED

- 4-6 Hours

Time to install this should take between 4-6 hours based on experience.

WARNINGS/CAUTIONS BEFORE STARTING INSTALLATION

Before you install this kit – Read and understand all instructions, warnings, cautions, and notes contained in this installation instruction guide. Consult your vehicle owner's manual for proper disconnection of electrical and lifting of vehicle if required for installation of this product.

This install may require some technical skills and knowledge of basic mechanical work. If you do not feel that you are capable of performing this install please take this product to a trained professional.

After reading this guide please contact us with any questions or concerns before installing product.
Customer Service: 855-680-9595

DV8 Offroad is not responsible for any bodily injury or harm to you or your vehicle as a result of an improper install.

Proper installation of this kit required knowledge of the factory recommended procedures for removal and installation of original equipment components. We recommend that the factory shop manual and any special tools needed to service your vehicle be on hand during the installation. Installation of this kit without proper knowledge of the factory recommended procedures may affect the performance of these components and the safety of the vehicle

- Always wear eye protection when operating power tools

Inspect all contents of this package to make sure product is not damaged and all installation hardware has been included. If parts are missing from kit, please be prepared to provide the following information

1. Name of purchase location
2. Bar Code on side of box
3. Date above bar code
4. Date inside box cover



INSTALLATION **MANUAL**

FACTORY BUMPER UNINSTALL

STEP 1 | Use a 10mm socket to remove the fasteners securing the fender flare to the vehicle.



STEP 2 | Using firm pressure, pull the fender flare away from the truck to the side to release the clips.

Once released, pull the side of the bumper down slightly and to the side to release the clips between the bumper and fender. Take your time to not break any of these clips.



STEP 3 | Reach behind and underneath the bumper to remove the black plastic trim by pressing out the clips from the inside.

You can gently pull from the outside as well, but do not allow them to bend or the clips will break.



INSTALLATION MANUAL

STEP 4 | Use a trim clip tool to remove the push clips next to the wiring plugs located next to the headlights at both ends of the vehicle.

Then disconnect the plugs.

Note: Number of wire connectors may vary based on options/trim level of the vehicle.



STEP 5 | Disconnect the wiring plug located between the bumper and radiator in the center section of the vehicle.



INSTALLATION MANUAL

STEP 6 | Use a trim clip tool to remove the fasteners securing the wiring plugs located behind the bumper in the fender well area on both sides of the vehicle.

Then disconnect the plugs.

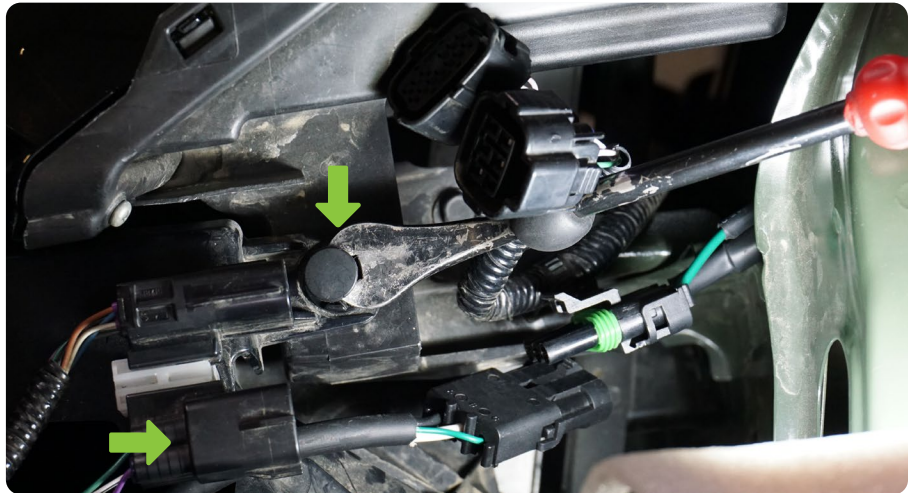

STEP 7 | Disconnect the wiring plugs located behind the grille on the passenger side of the vehicle underneath the grille's upper mounts.



INSTALLATION MANUAL

STEP 8 | Use a 10mm socket to remove the bolts securing the grille to the vehicle.

These are located:

- Along the radiator frame brace under the hood.
- Underneath the vehicle along the bottom of the bumper.
- Behind the trim pieces on both sides of the vehicle underneath the headlights.

Note: Assistance is recommended to prevent damage to the grille/bumper.

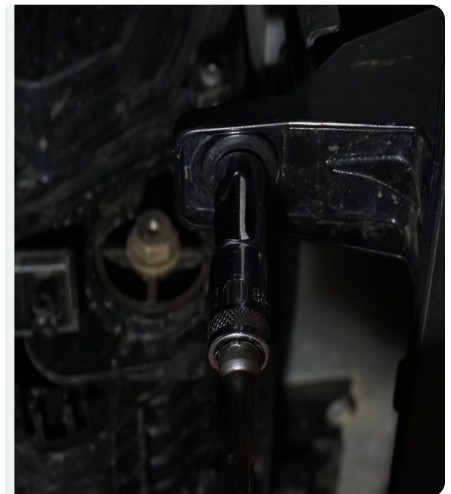
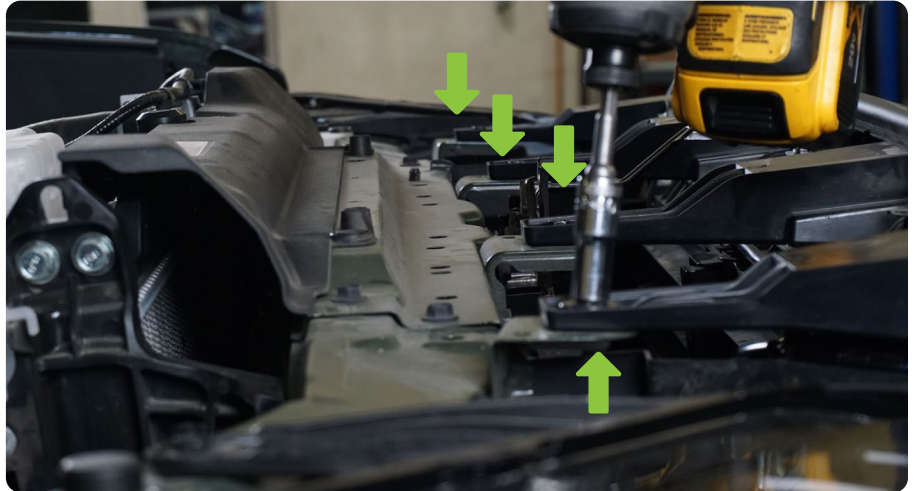

STEP 9 | Remove the wiring connector from the air dam motor, and use a trim clip tool to undo the clip securing the wiring harness to the motor.

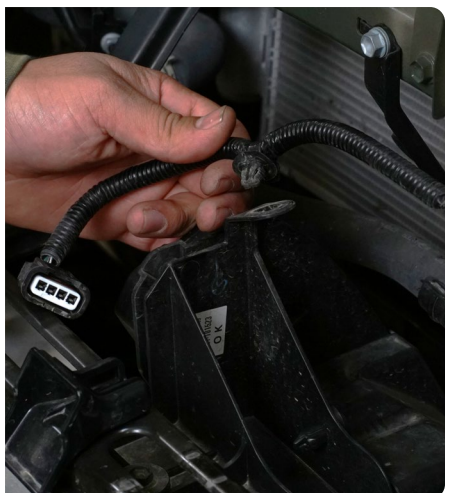
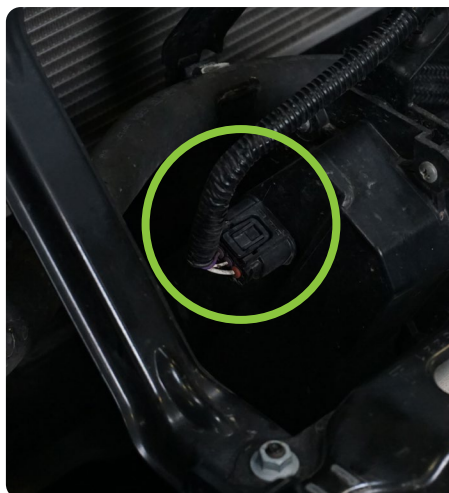

INSTALLATION MANUAL

STEP 10 | Use a 17mm socket or wrench to remove the bolts securing the crash bar.

Then set the crash bar and braces off to the side.

Some vehicles came equipped with an air dam motor. If the vehicle has an air dam motor, unplug and remove it at this time.

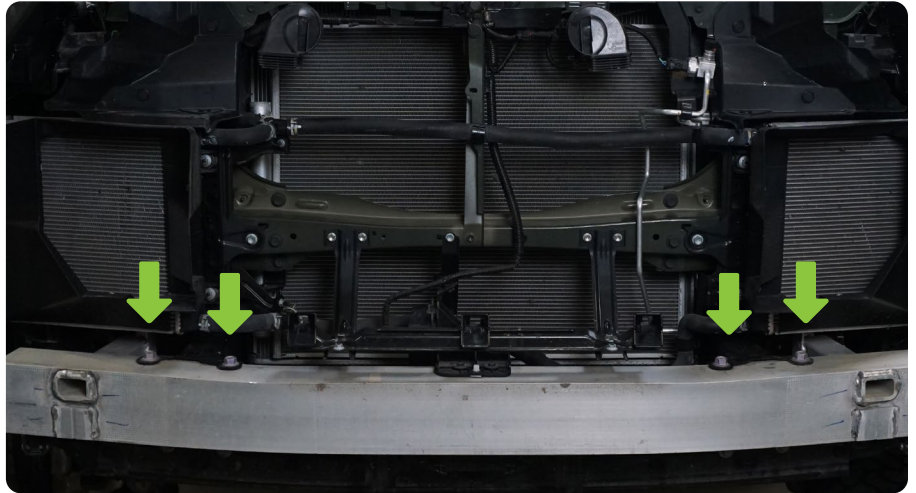

STEP 11 | Use a 10mm socket to remove bolts securing the vertical cross braces from the vehicle.



INSTALLATION MANUAL

STEP 12 | Use a 10mm socket to remove the bolt securing the cooling hose bracket and set off to the side.



STEP 13 | Use a 12mm socket to remove the bolts securing the skid plate if you have one, and set it off to the side.

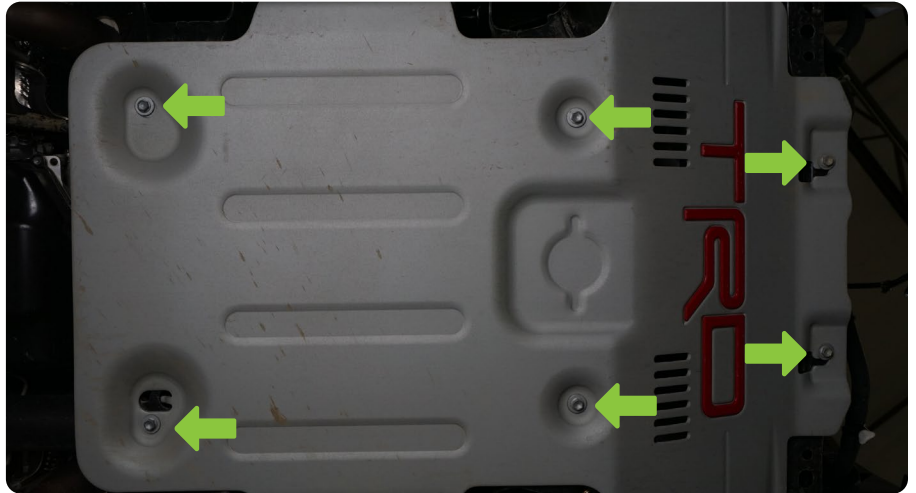

INSTALLATION MANUAL

Begin by unpacking all items and inspecting for missing pieces or damage. If you have any concerns, please contact the company the product was purchased from. Extra hardware may be included with the product.

HARDWARE INCLUDED

- | | |
|--------------------------|--------------------------|
| (12) M14x35 Hex Bolts | (1) M8x30 Hex Bolt |
| (24) M14 Flat Washers | (3) M6x25 Allen |
| (12) M14 Nylon Lock Nuts | (4) M6x20 Allen |
| (4) M12x35 Hex Bolts | (5) M6 Nylon Lock Nuts |
| (8) M12 Flat Washers | (17) M6 Flat Washers |
| (4) M12 Nylon Lock Nuts | (3) M6 Split Washers |
| (6) M8x30 Allen Head | (1) M6 Wide Flat Washers |
| (9) M8 Flat Washers | (1) M6x30mm Hex |
| (1) M8 Wide Flat washer | |
| (7) M8 Nylon Lock Nuts | |

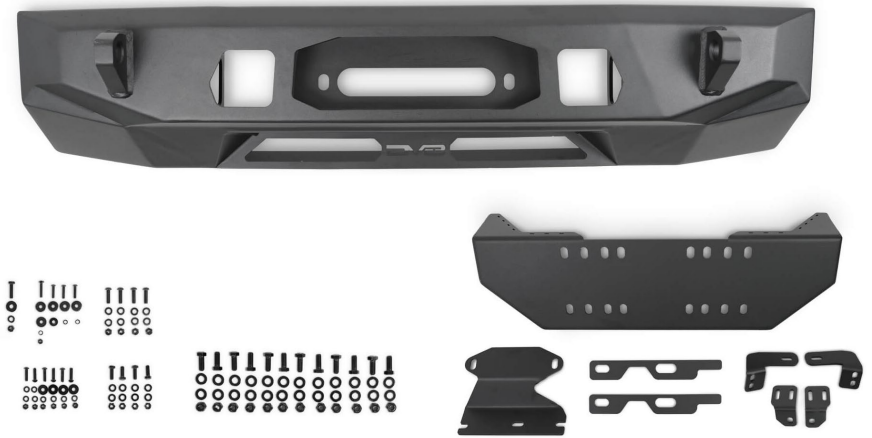

STEP 14 | Using a pry tool, unclip the (23) trim clips securing the Bumper Face.

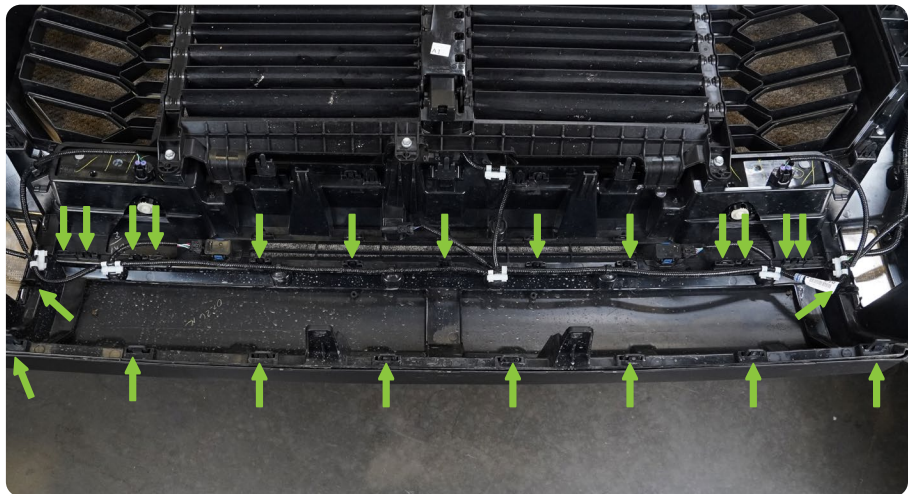

INSTALLATION MANUAL

STEP 15 | Unclip bumper trim pieces to allow removal of Bumper Face.



Remove Bumper Face.



STEP 16 | Using a Pry Tool, unclip the 5 wiring harness hold downs.

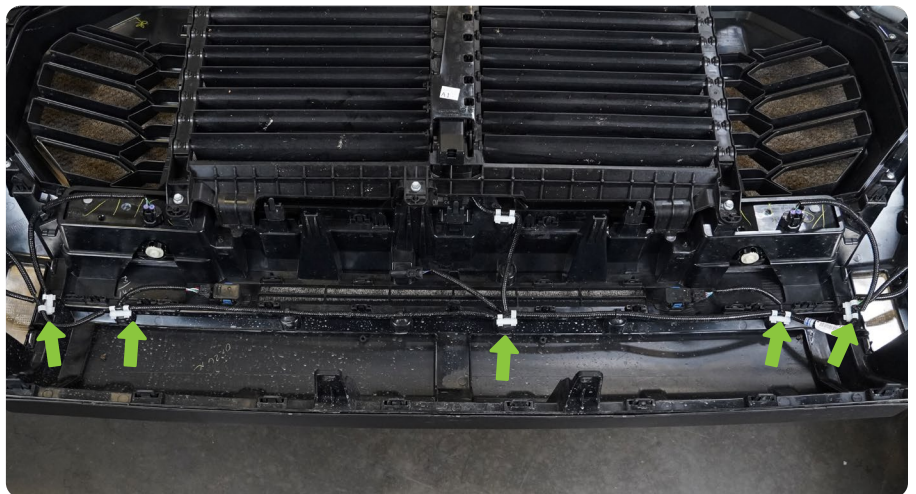

INSTALLATION MANUAL

STEP 17 | Secure the wiring harness out of the way with zip ties.

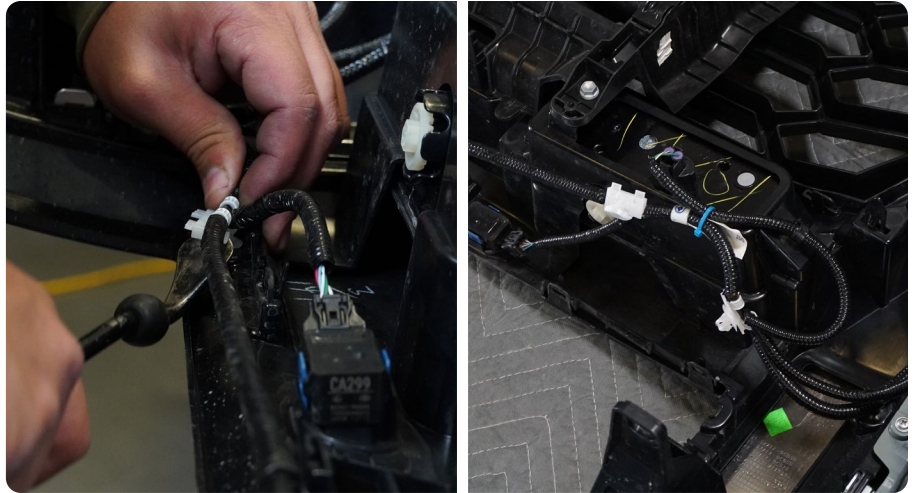

STEP 18 | With the bumper face removed and wiring harness's secured out of the way, use a marker to draw a cut line.

When cutting the area below the mesh, the cut line should be above the clips.

On the top edge on each side of the mesh, the cut line should be below the clips, as they are necessary structure for the grille when re-installed.

(See next page for images of a cut bumper)

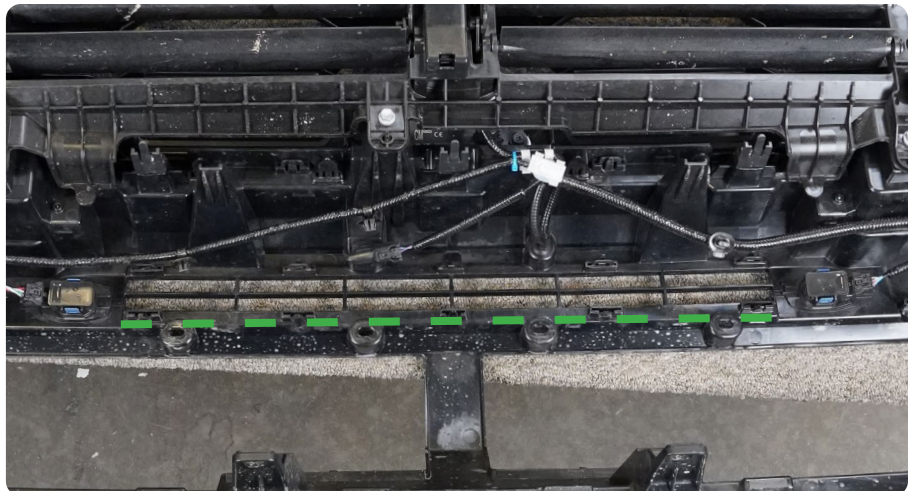

INSTALLATION MANUAL

STEP 19 | Using your preferred cutting tool, cut the bumper following the cut line previously drawn.

Use a File or sandpaper to smooth out any rough edges

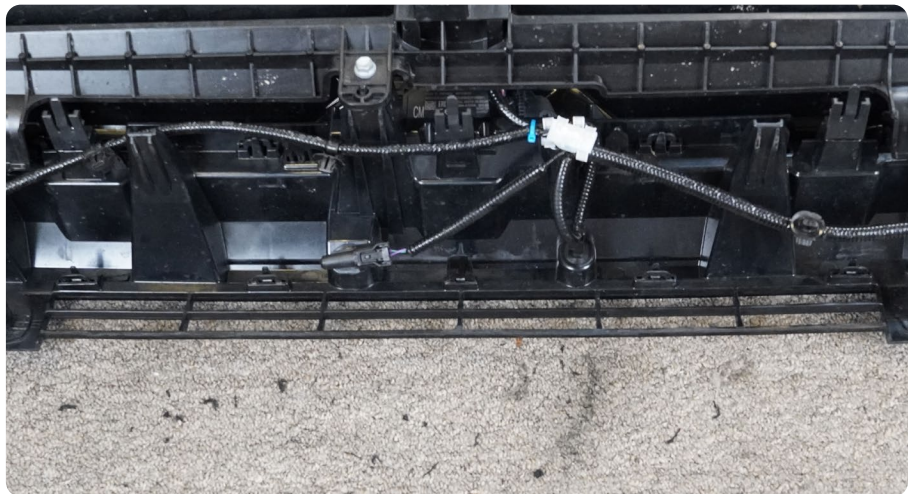
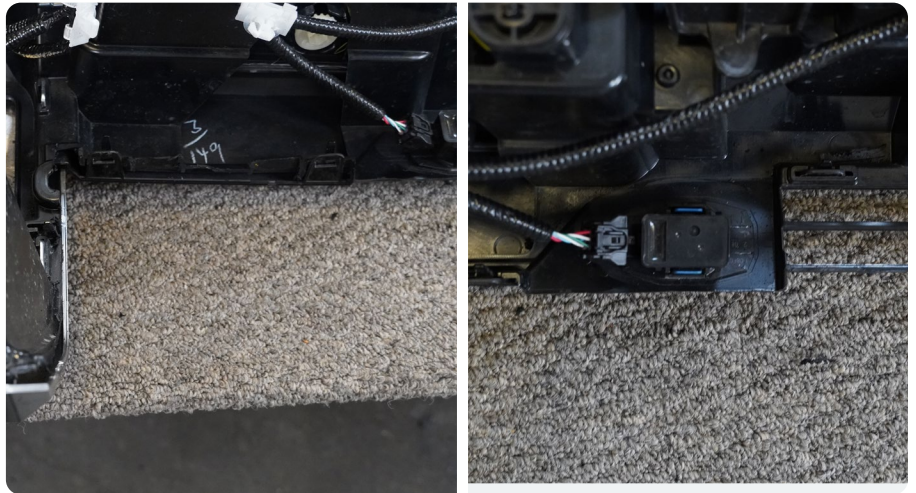

STEP 20 | Using a 5mm Allen bit, 13mm wrench and provided M8 hardware attach the bumper support brackets to each side of the DV8 center mount.



INSTALLATION MANUAL

STEP 21 | If planning to run a light bar or pod lights install those accessory's at this time.

Using a 4mm Allen bit, 10mm wrench and provided M6 hardware install light bar brackets with button head on top to allow for winch plate clearance.

Install light bars and pod lights using hardware provided with light kit.



INSTALLATION MANUAL

STEP 22 | On the air dam motor use a trim clip tool to remove the cap.

Then use a 14mm socket and wrench to remove the bolts and nut securing the arm.



STEP 23 | Remove the black caps, the white plastic spacers and the spring from the inside, and set the arm off to the side.

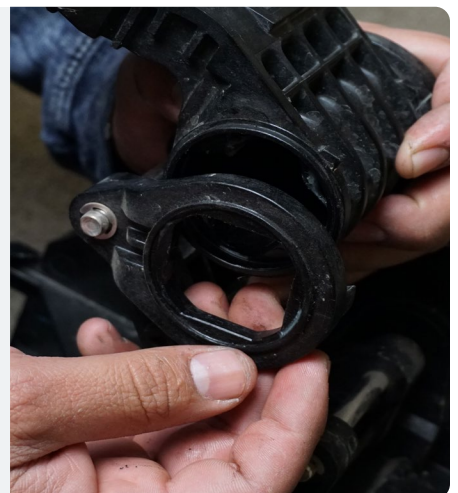
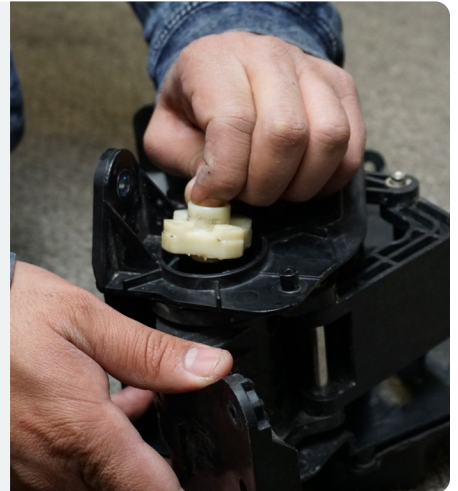

INSTALLATION MANUAL

STEP 24 | Cut the flat section off of the arm as shown.



STEP 25 | Place the arm back into the motor and install the spring, white plastic spacers, and black caps. Then secure using the factory hardware with a 14mm wrench and socket.



INSTALLATION MANUAL

STEP 26 | Trim the plastic section with the two factory mounting holes off of the motor as shown.

HOLES WITH THE ARROWS WILL BE REUSED, DO NOT CUT THESE

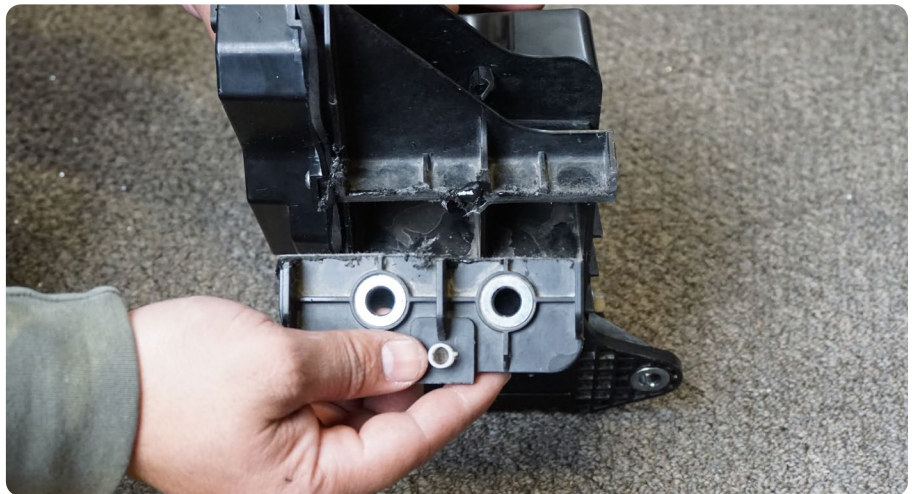
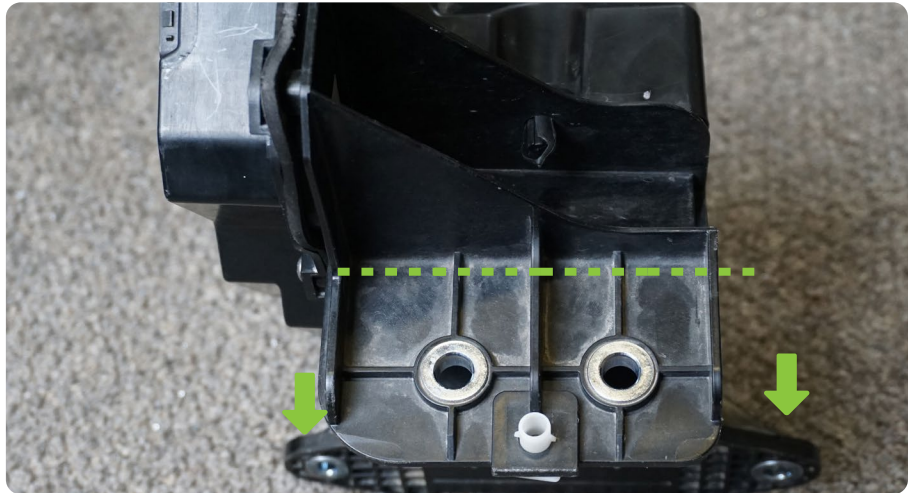

STEP 27 | Trim the small remaining mounting tab off the motor as shown.



INSTALLATION MANUAL

STEP 28 | Replace cap on the air dam motor.



STEP 29 | Use a 10mm socket to remove the bolt securing the cooling hoses to bracket located in front of the radiator on the passenger side.



INSTALLATION MANUAL

STEP 30 | Remove the cooling hoses running in front of the radiator from their plastic retaining clips.



STEP 31 | Use a 10mm socket to remove the bolt securing the vertical cross brace. Slip the cooling hose behind the cross brace and re-secure using the factory hardware.

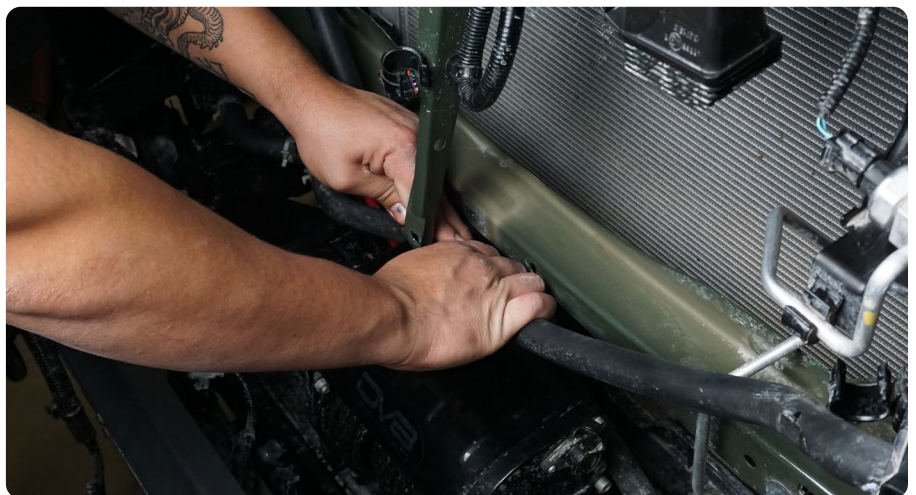

INSTALLATION MANUAL

STEP 32 | On the passenger side, push back on the hose mounting bracket to give the hoses some slack and then re-secure the hoses using the factory hardware and a 10mm socket.

Replace the upper cooling hose in its plastic retaining clips

Tip: Zip tie the lower cooling hose to the center brace at this time ensuring it clears the winch if you are running one. Hoses should not be too taugt or too loose and should not collide with anything.



STEP 33 | Use the provided M6 hardware with a 4mm allen bit and 10mm wrench to secure the air dam motor to the provided bracket.

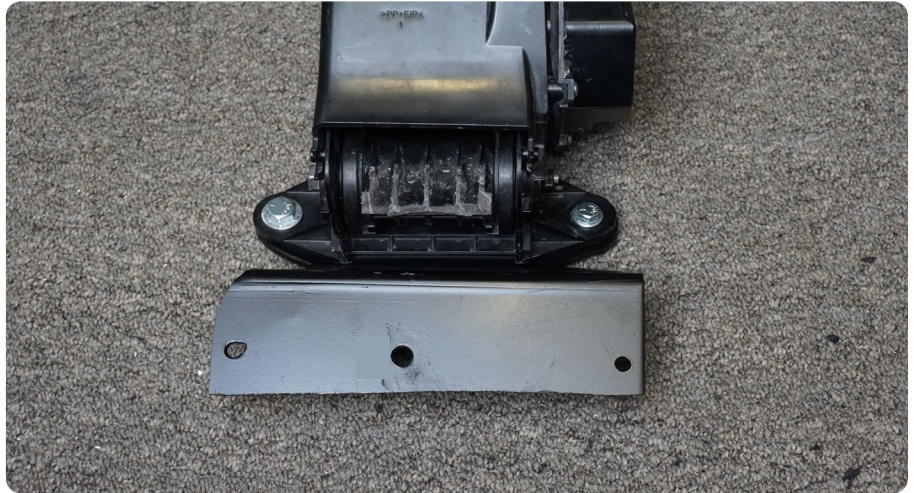

STEP 34 | Install the air dam bracket onto the horizontal cross brace using the provided M6 hardware and a 4mm allen bit. Connect the air dam motor wiring plug.

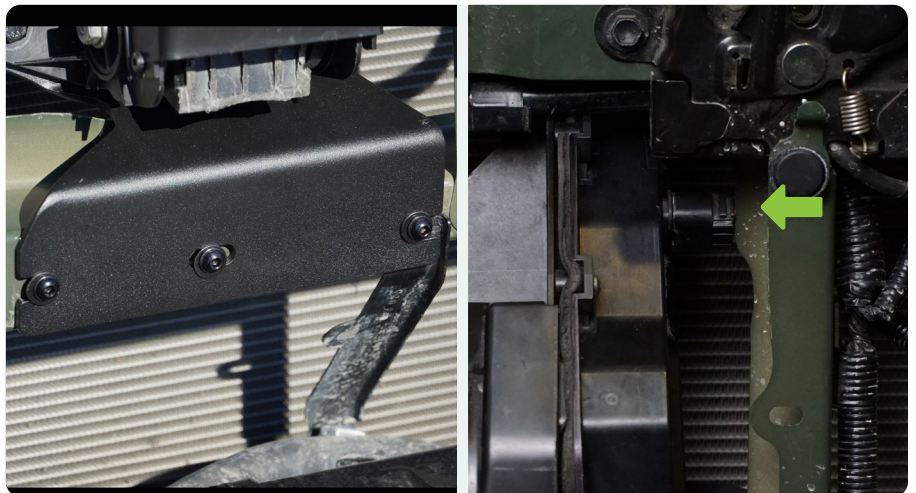

INSTALLATION MANUAL

STEP 35 | Secure air dam motor wiring harness to vertical center cross brace using the factory clip.

Note: Air dam motor should have a healthy gap between it and the radiator. The radiator hose running behind the air dam motor should not be too taught or too loose, and should also have a gap between it and the radiator. Use a zip-tie for additional security, if desired.



INSTALLATION MANUAL

STEP 36 | If planning to utilize a winch, install the winch on to the winch plate at this time using hardware supplied in winch kit.

Using a 21mm socket, 22mm & 21mm wrench and provided M14 hardware, install the winch and winch plate on to the DV8 center mount.

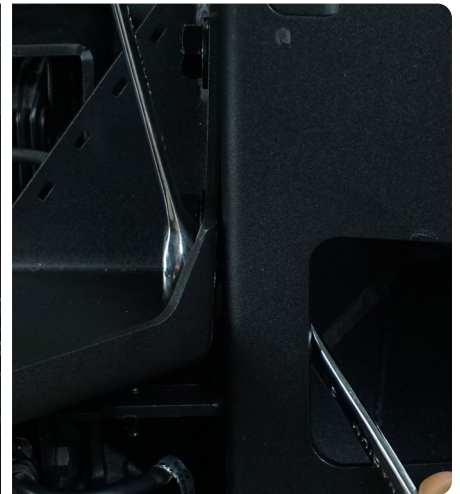

STEP 37 | See step 38 for information about the optional spacer plates provided with the bumper.

With assistance loosely secure the DV8 Center Mount to the vehicle using provided M14 hardware and using 21mm & 22mm wrenches. At this point, the bumper should be able to be adjusted side to side.

Mount the upper hardware first with the threads facing up.



INSTALLATION MANUAL

STEP 38 | Optional Step:

Provided are (2) Center Mount Spacers, these spacer provide a slight gap between the center mount and grille.

If a flush install finish is desired do not install center mount spacers.



Using a 21mm socket, 22mm wrench and provided M14 hardware secure the spacer plates to the center mount.



STEP 39 | With the grille/bumper cut and the DV8 Center Mount installed, reinstall the grille/bumper.

Check the fitment of the grille bumper and determine if any additional trimming needs to be done before continuing with install.

Gaps around the bumper should be even, and there should be clearance between the grille and bumper if the spacer plates have been installed.



INSTALLATION MANUAL

STEP 40 | Carefully reattach fender flares by pressing the clips into place.



INSTALLATION MANUAL

STEP 41 | Reattach the bumper on each side to the wheel well using a 10mm socket and the (6) factory hardware previously removed. The factory inner fender should be sandwiched between the bumper and fender flare.



STEP 42 | Reattach the bumper to the fender liner using a 10mm socket and factory hardware previously removed.



STEP 43 | Attache the Bumper support brackets using a 5mm Allen bit, a 13mm wrench and the provided M8 hardware.



INSTALLATION MANUAL

STEP 44 | Reattach the top of the grille using factory hardware previously removed and a 10mm socket.

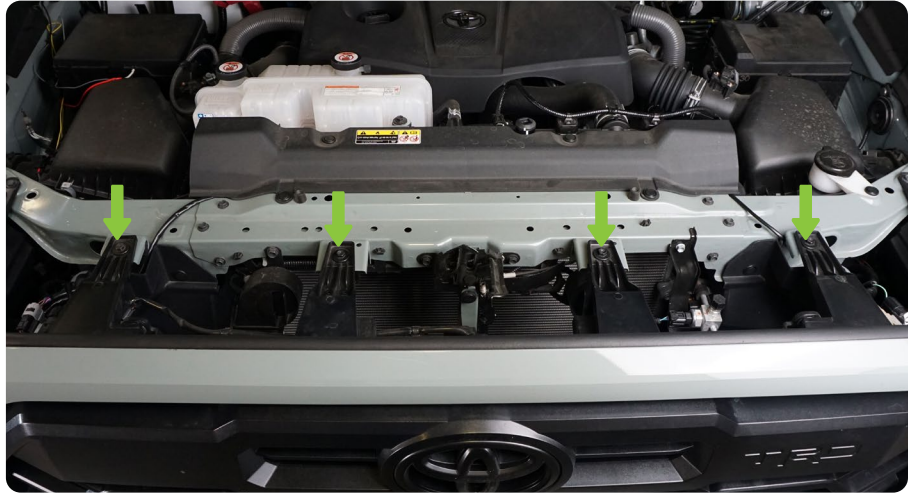

STEP 45 | Install all push pins and reconnect all wiring harness's previously removed or disconnected.



INSTALLATION MANUAL

STEP 46 | Double check that all hardware is secure.

Congratulations the DV8 Center Mount installation is now complete.

